

Item code: 7273028

Slim Double Wall Drawer (Low Drawer) Ray Hộp Slim (chiều cao thấp)



Load capacity: 35kgs
Nominal length: 500mm
Height of drawer sides: 90mm

Tải trọng: 35kg
Chiều dài ray: 500mm
Chiều cao thành hộp kéo: 90mm



Installation dimensions / Kích thước lắp đặt
LW = Internal cabinet width / Chiều rộng lọt lòng thùng tủ
KB = Cabinet width / Chiều rộng thùng tủ
NL = Slide length / chiều dài ray
LT = Internal cabinet depth / chiều sâu lọt lòng tủ

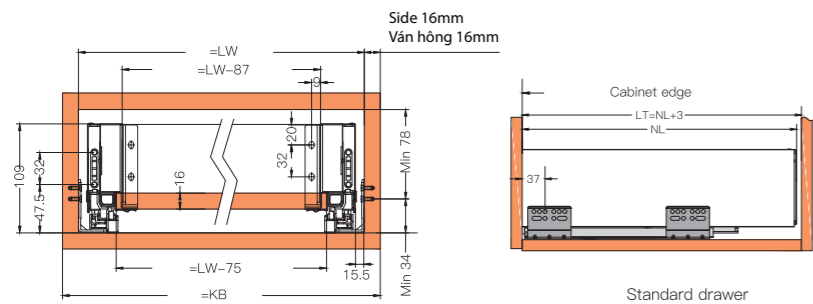

Hole position / Vị trí lỗ vít

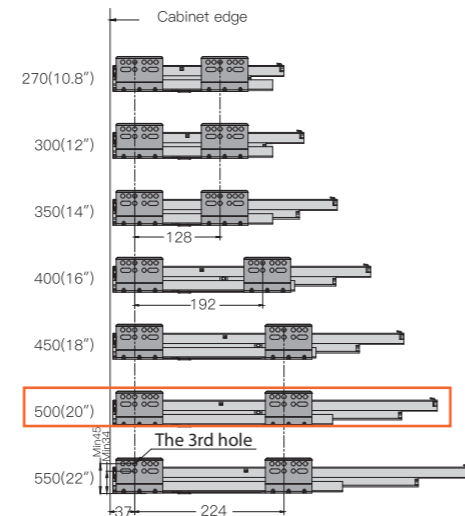

Accessories

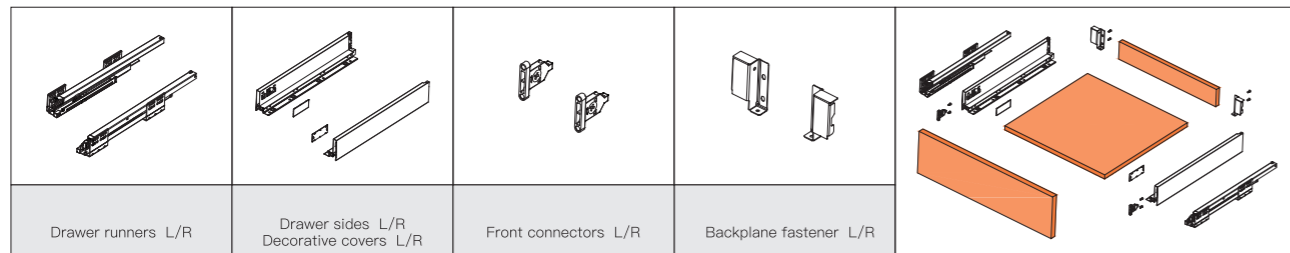

Drawer size and drilling

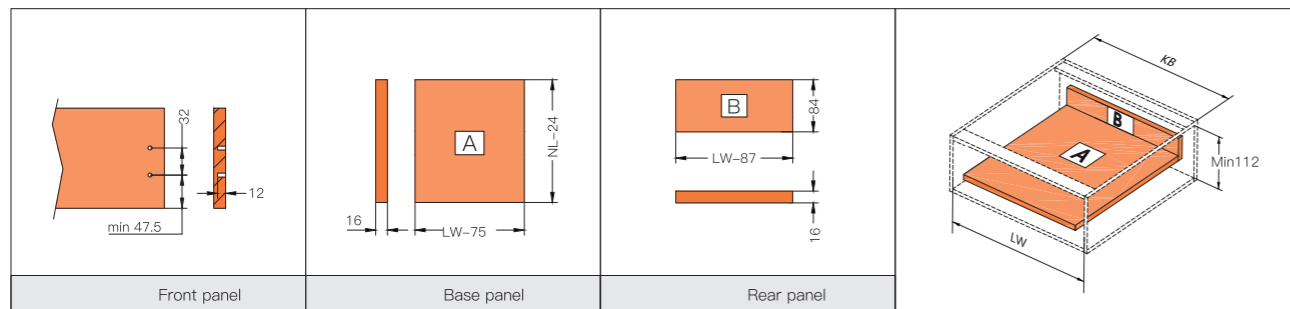

Item code: 7273029

Slim Double Wall Drawer (Medium Drawer) Ray Hộp Slim (chiều cao vừa)



Load capacity: 35kgs
Nominal length: 500mm
Height of drawer sides: 122mm

Tải trọng: 35kg
Chiều dài ray: 500mm
Chiều cao thành hộp kéo: 122mm



Installation dimensions / Kích thước lắp đặt
LW = Internal cabinet width / Chiều rộng lọt lòng thùng tủ
KB = Cabinet width / Chiều rộng thùng tủ
NL = Slide length / chiều dài ray
LT = Internal cabinet depth / chiều sâu lọt lòng tủ

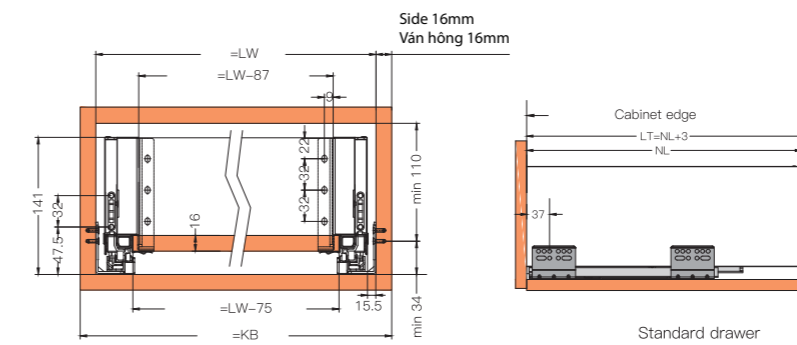

Hole position / Vị trí lỗ vít

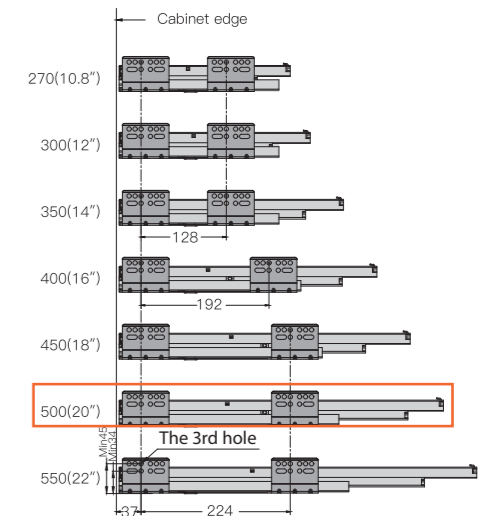

Accessories

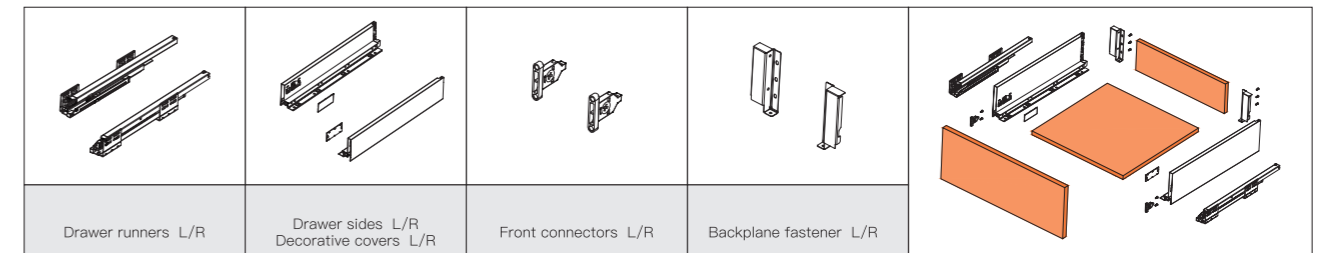

Drawer size and drilling

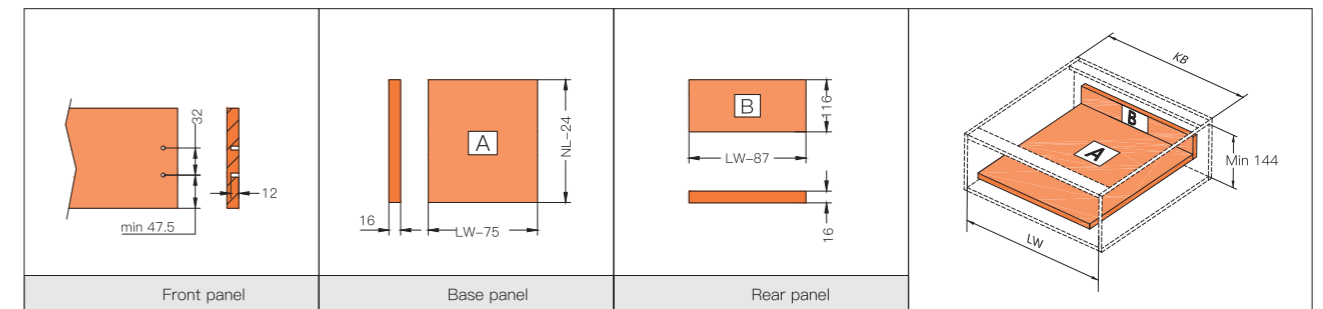

Item code: 7273820

Inner Slim Double Wall Drawer (Low Drawer) Ray Hộp Âm Slim (chiều cao thấp)

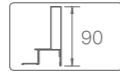

Load capacity: 35kgs
Nominal length: 500mm
Height of drawer sides: 90mm

Tải trọng: 35kg
Chiều dài ray: 500mm
Chiều cao thành hộp kéo: 90mm



Installation dimensions / Kích thước lắp đặt
LW = Internal cabinet width / Chiều rộng lọt lòng thùng tủ
KB = Cabinet width / Chiều rộng thùng tủ
NL = Slide length / chiều dài ray
LT = Internal cabinet depth / chiều sâu lọt lòng tủ

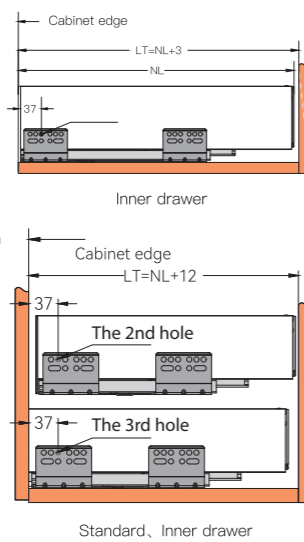
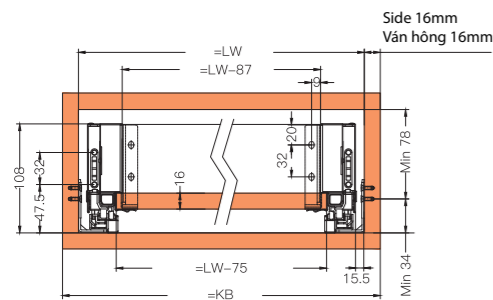

Hole position / Vị trí lỗ vít

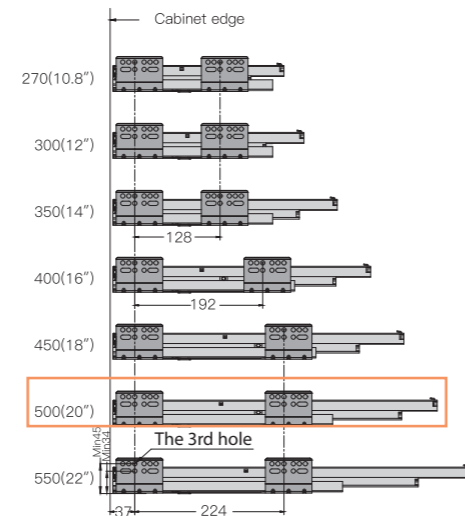

Accessories

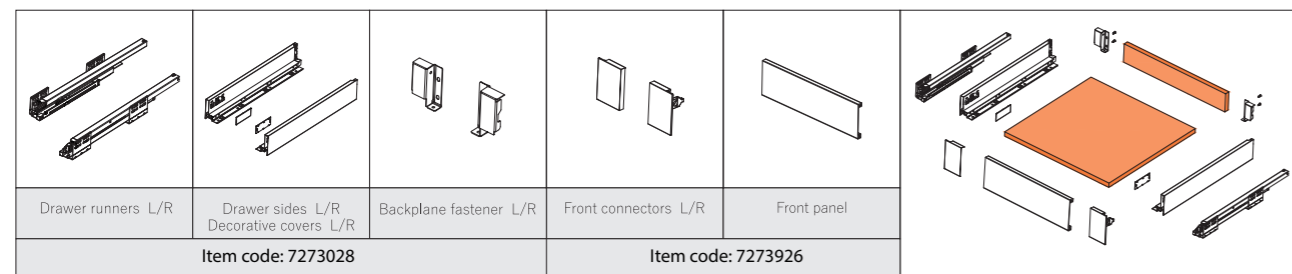

Drawer size and drilling

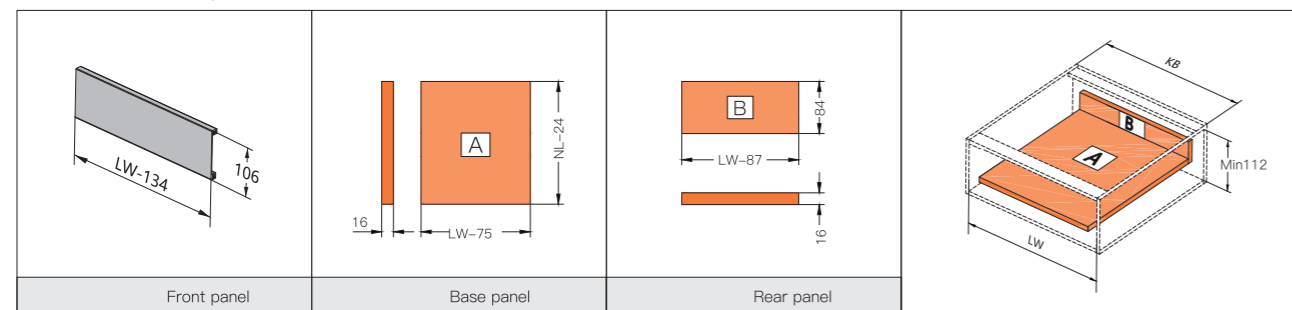

Item code: 7273821

Inner Slim Double Wall Drawer (Medium Drawer) Ray Hộp Âm Slim (chiều cao vừa)

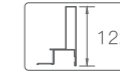

Load capacity: 35kgs
Nominal length: 500mm
Height of drawer sides: 122mm

Tải trọng: 35kg
Chiều dài ray: 500mm
Chiều cao thành hộp kéo: 122mm



Installation dimensions / Kích thước lắp đặt
LW = Internal cabinet width
(Chiều rộng lọt lòng thùng tủ)
KB = Cabinet width / Chiều rộng thùng tủ
NL = Slide length / chiều dài ray
LT = Internal cabinet depth / chiều sâu lọt lòng tủ

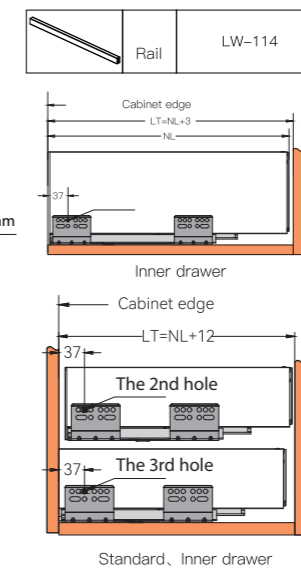
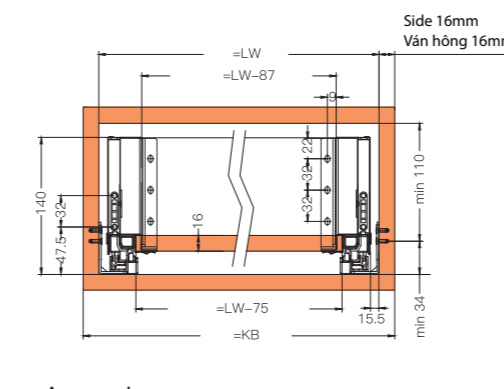

Hole position / Vị trí lỗ vít

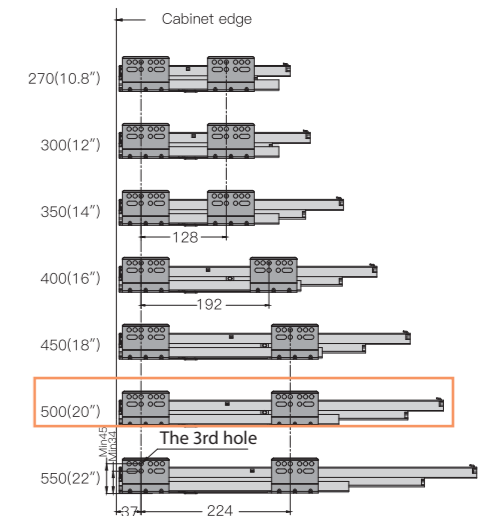

Accessories

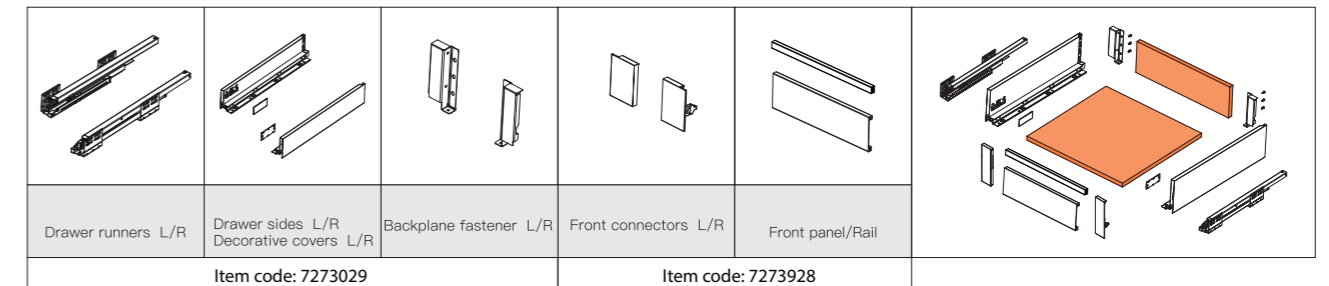

Drawer size and drilling

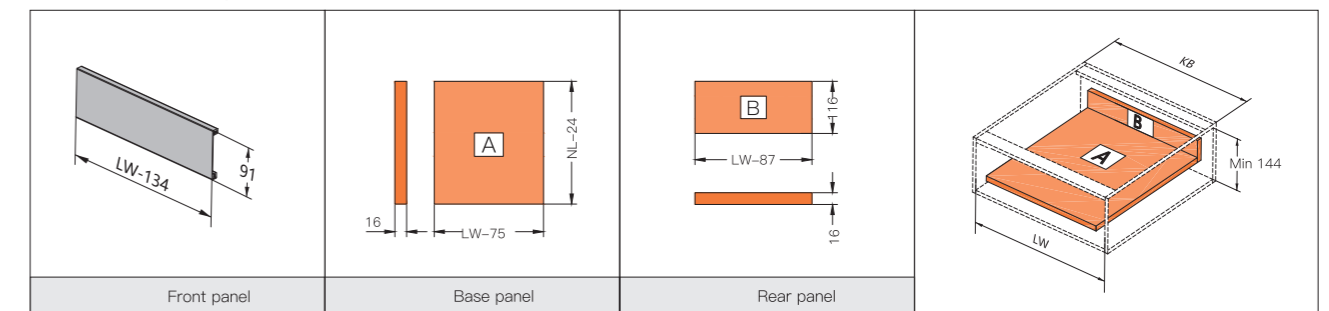

Item code: 7273822

Inner Slim Double Wall Drawer (Hight Drawer) Ray Hộp Âm Slim (chiều cao lớn)

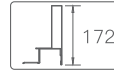

Load capacity: 35kgs
Nominal length: 500mm
Height of drawer sides: 172mm

Tải trọng: 35kg
Chiều dài ray: 500mm
Chiều cao thành hộp kéo: 172mm



Installation dimensions / Kích thước lắp đặt

LW = Internal cabinet width

(Chiều rộng lọt lòng thùng tủ)

KB = Cabinet width / Chiều rộng thùng tủ

NL = Slide length / chiều dài ray

LT = Internal cabinet depth / chiều sâu lọt lòng tủ

Side 16mm

Ván hông 16mm

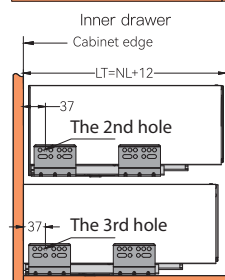
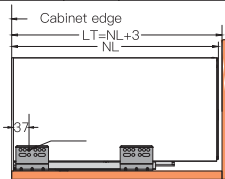
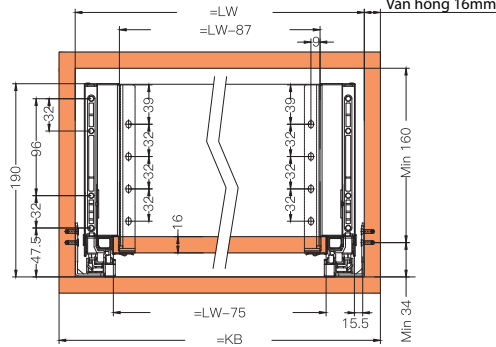

Standard, Inner drawer

Hole position / Vị trí lỗ vít

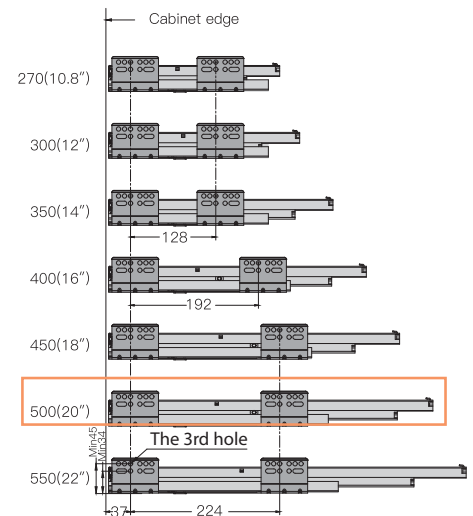

Accessories

Item code: 7273030		Item code: 7273930			

Drawer size and drilling

Front panel	Base panel	Rear panel	